

# Application of open-source software in the design of microfluidic devices

<sup>1</sup>Pimenta F., Sousa R., Alves M.A.

Departamento de Engenharia Química, Faculdade de Engenharia da Universidade do Porto, 4200-465 Porto, Portugal

<sup>1</sup> Email address: [fpimenta@fe.up.pt](mailto:fpimenta@fe.up.pt)

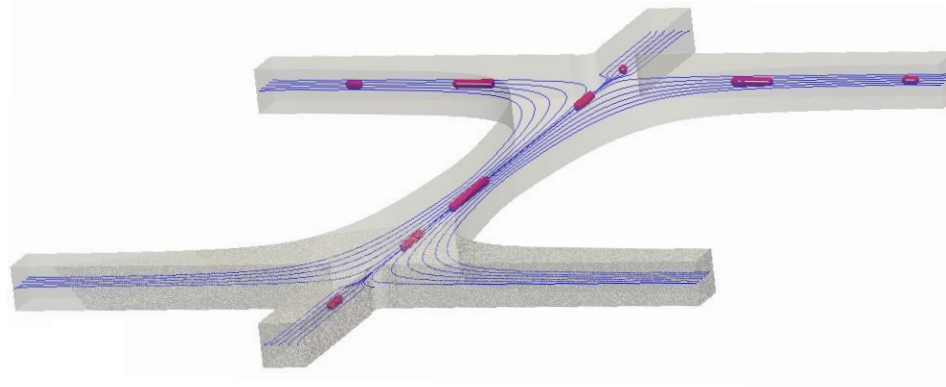

# Outline

- Overview
- Problem formulation
- Methods and Results
  - ✓ Shape-optimization
  - ✓ Experimental validation
  - ✓ Performance on viscoelastic flows
  - ✓ Brownian dynamics simulations
- Summary

# Overview

Microfluidic devices that impose an **extensional flow** are used in:

## Molecular stretching

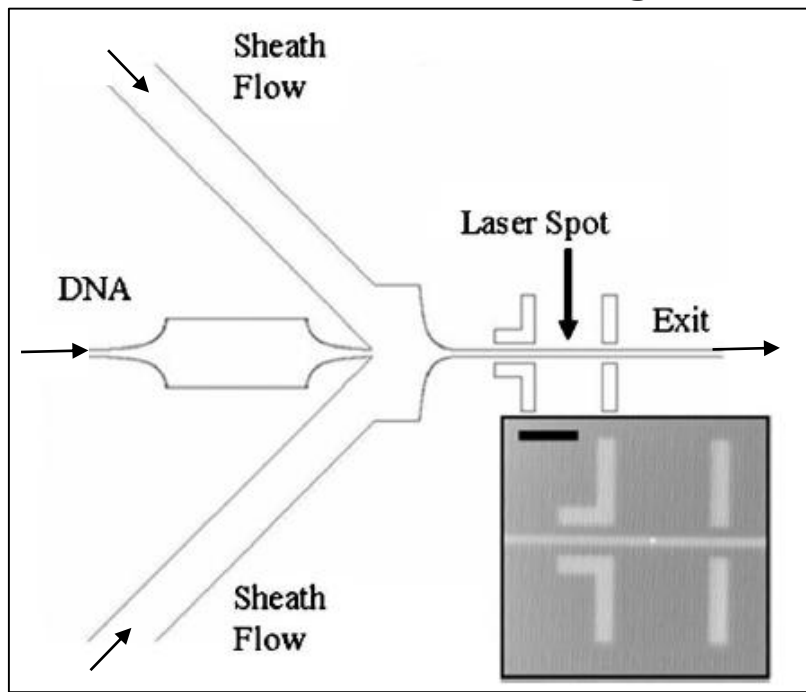

Adapted from: Krogmeier *et al.* (2007) *Lab Chip* 7: 1767–1774

## Rheometry

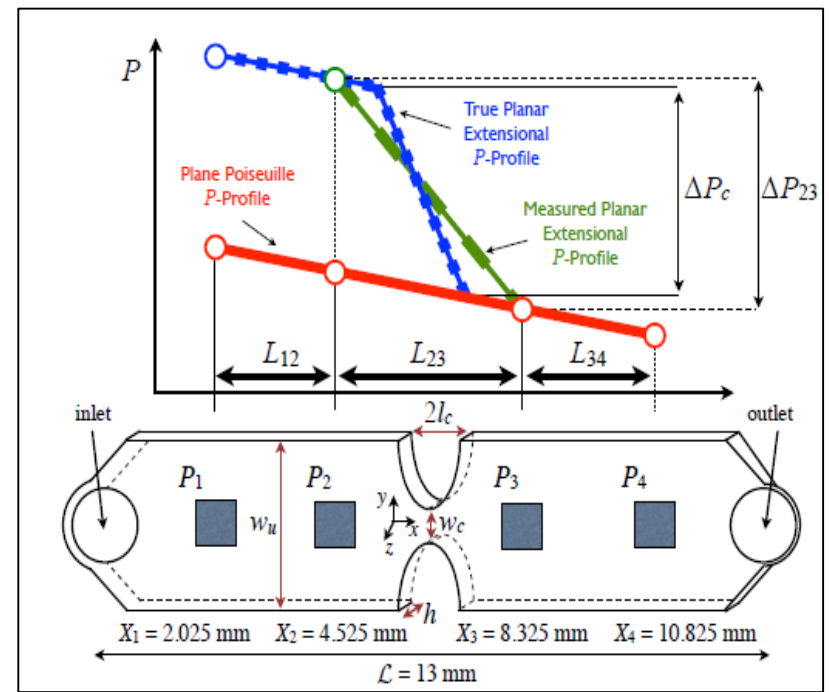

Adapted from: Ober *et al.* (2013) *Rheol. Acta* 52: 529–546

# Overview

Microfluidic devices that impose an **extensional flow** are used in:

Cellular classification

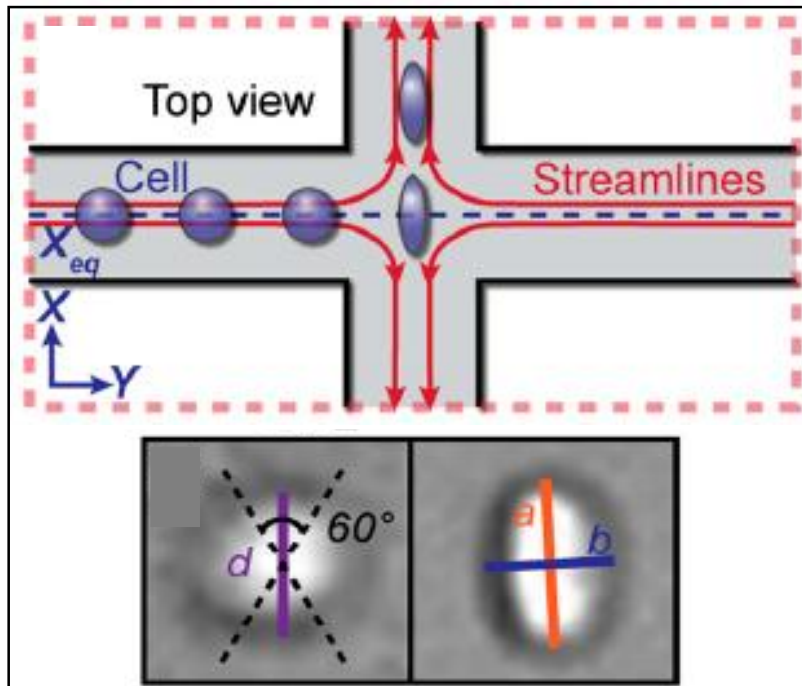

Adapted from: Gossett *et al.* (2012) *PNAS*  
109: 7630–7635

Rheological studies

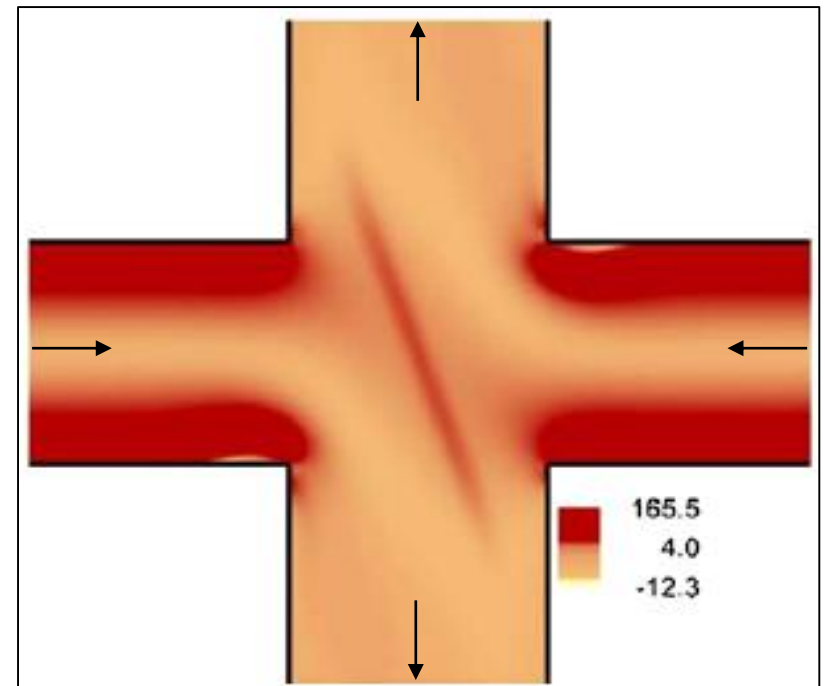

Adapted from: Rocha *et al.* (2009) *J. Non-Newtonian Fluid Mech.* 156: 58–69 4

# Problem formulation

**Drawbacks** of standard devices used for extensional flows:

- **Reduced** area of extensional flow;
- **Non-homogeneous** extensional flow field.

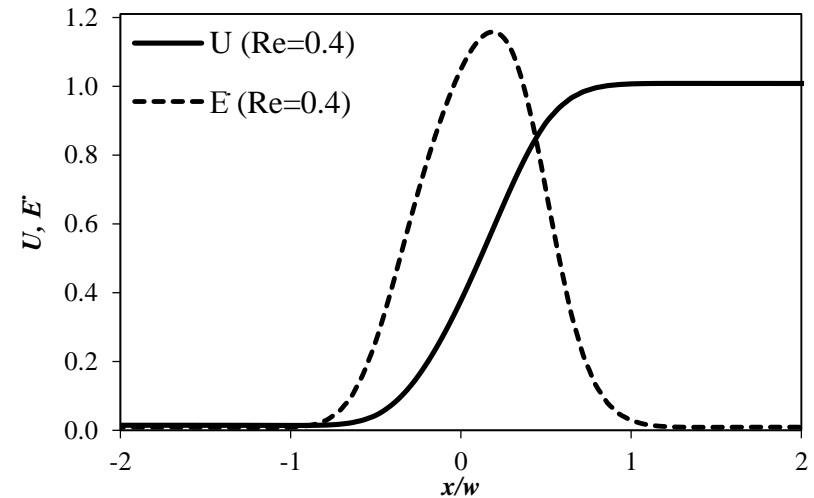
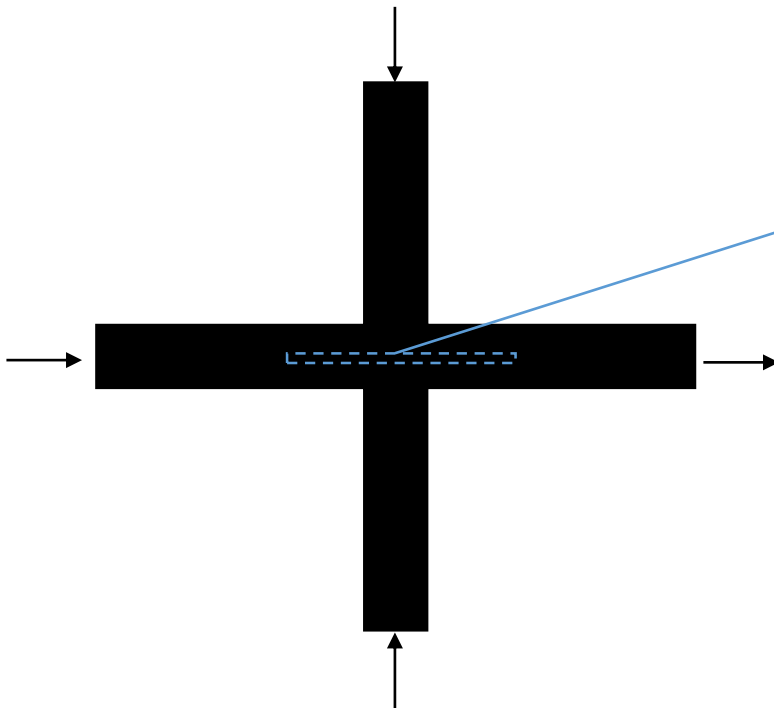

**Velocity and extensional rate profiles at the centerline**

# Problem formulation

**Purpose** of the present work:

**Optimization** of a **flow-focusing device** in order to produce a **homogeneous extensional flow field in a wide region...**

... using only **open-source** software.

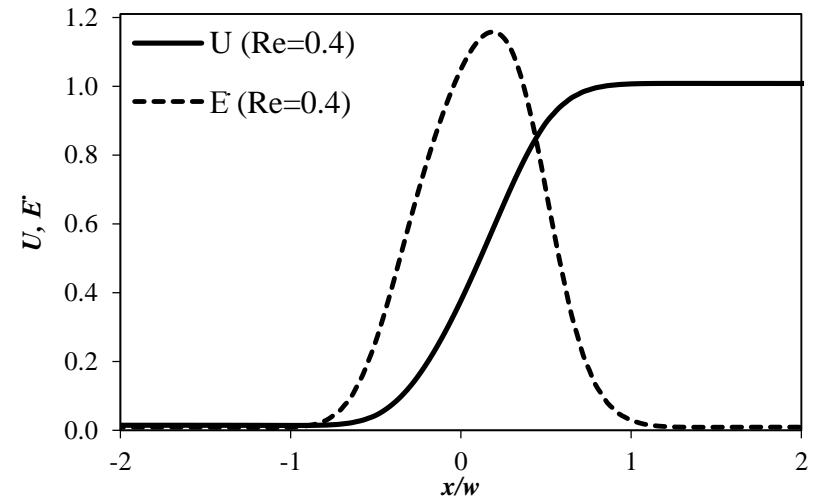
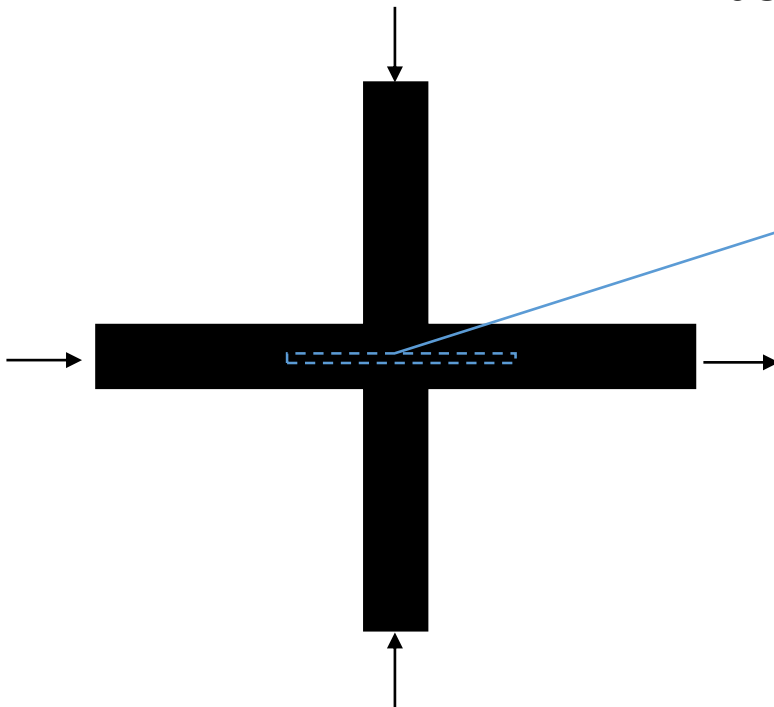

**Velocity and extensional rate profiles at the centerline**

# Methods and Results

# Shape-optimization

**Methods:** geometry and cost-function

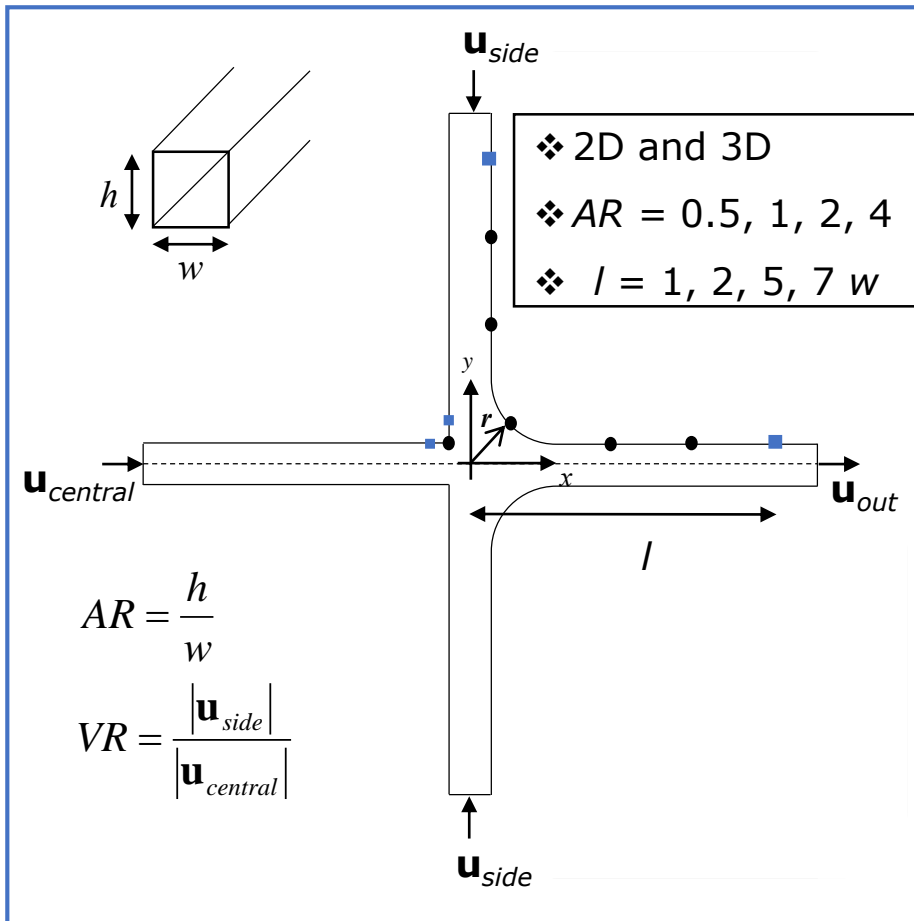

## 2 Cost functions

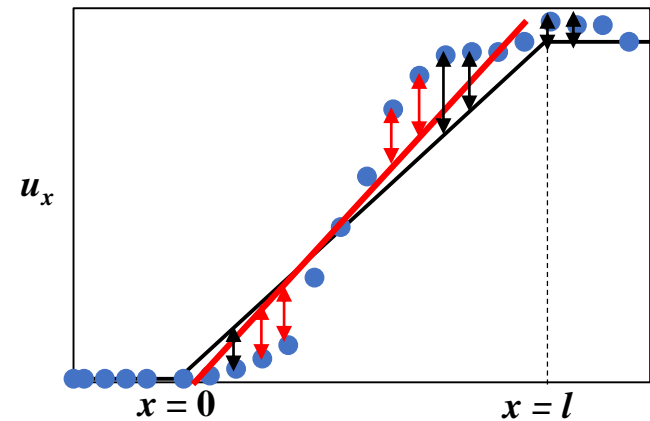

### Flow conditions:

- steady;
- laminar ( $Re = 0.4$ );
- $VR = 100$ .

### Fluid characteristics:

- Newtonian;
- incompressible.

# Shape-optimization

*Methods: workflow*

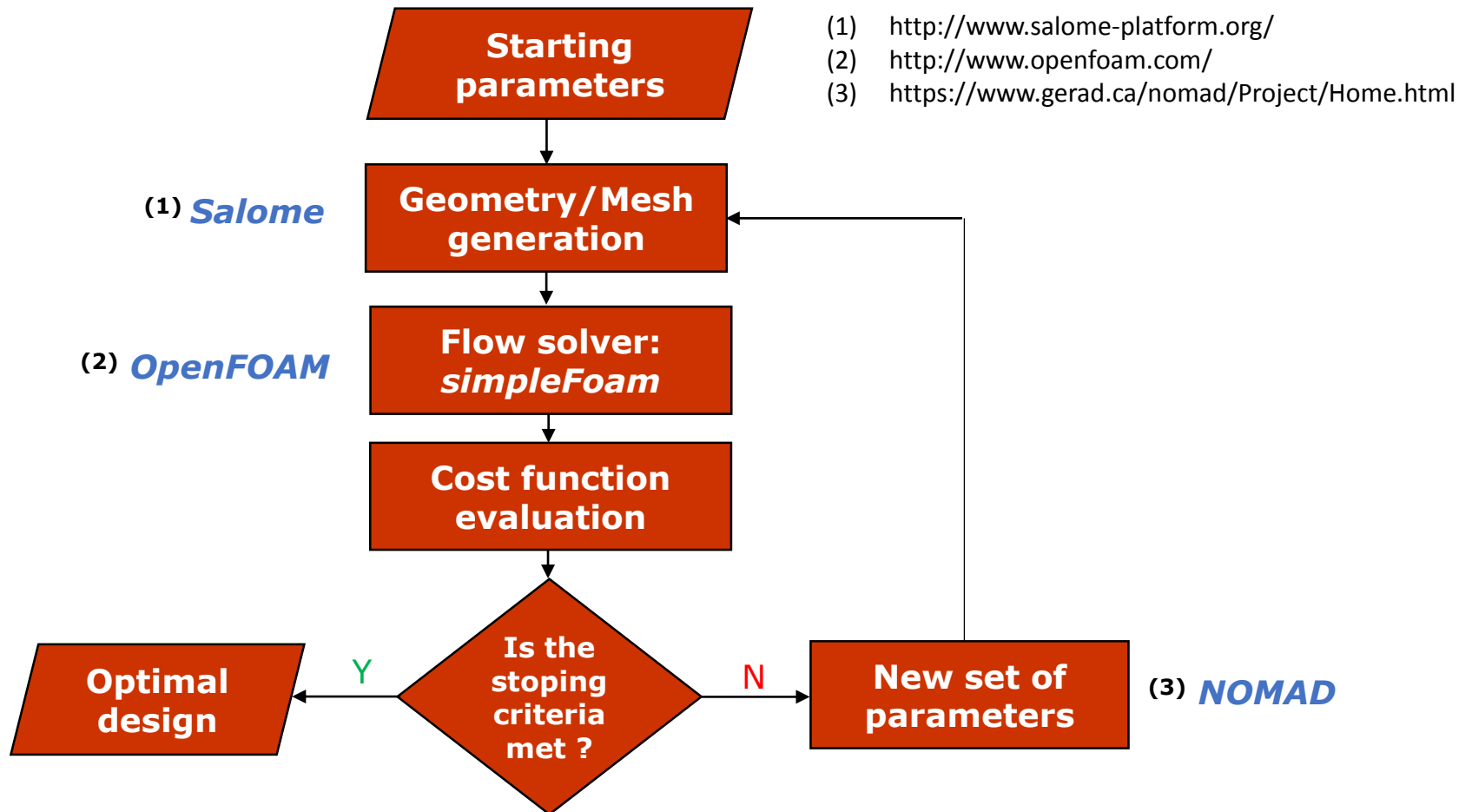

# Shape-optimization

*Results: simulations*

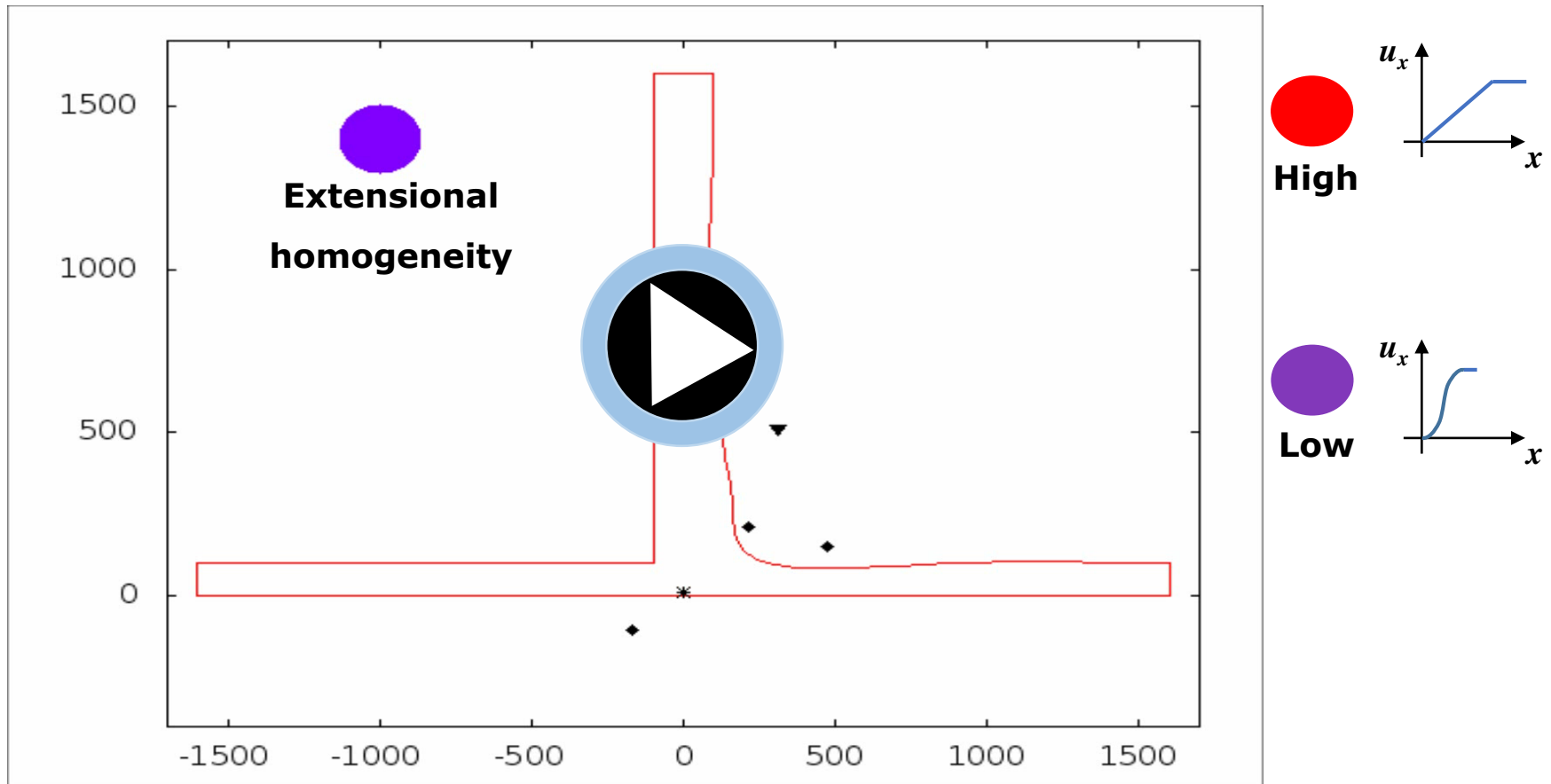

**NOMAD at work** (5 parameters, 600 iterations, only for demonstration!)

# Shape-optimization

*Results: simulations*

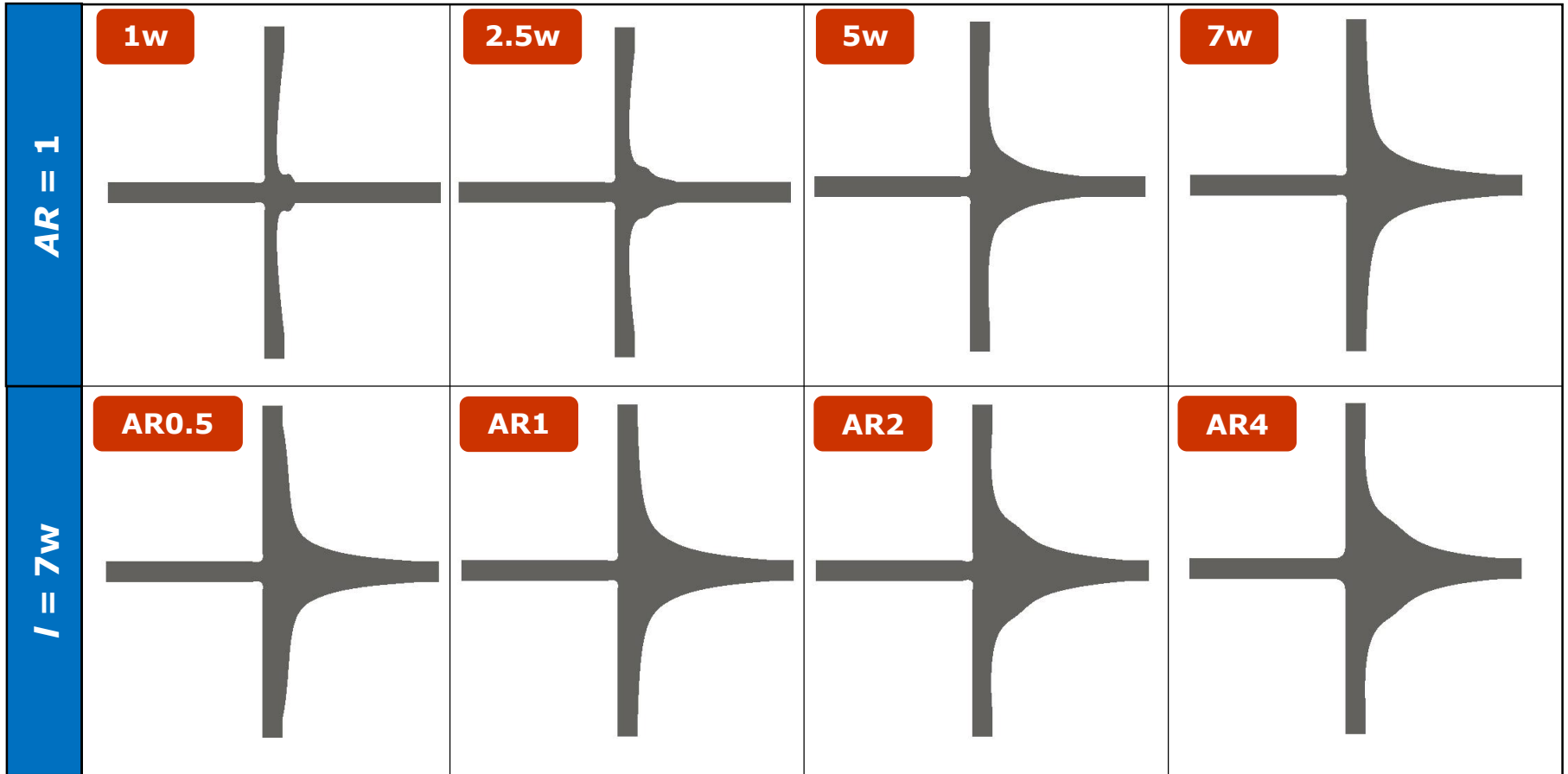

**Final optimized shapes for 3D cases**

# Shape-optimization

*Results: simulations*

$$U = u_x / (K / \bar{u}_{out} / l)$$

$$E = \dot{\epsilon} / (K / \bar{u}_{out} / l)$$

**Standard FFD**

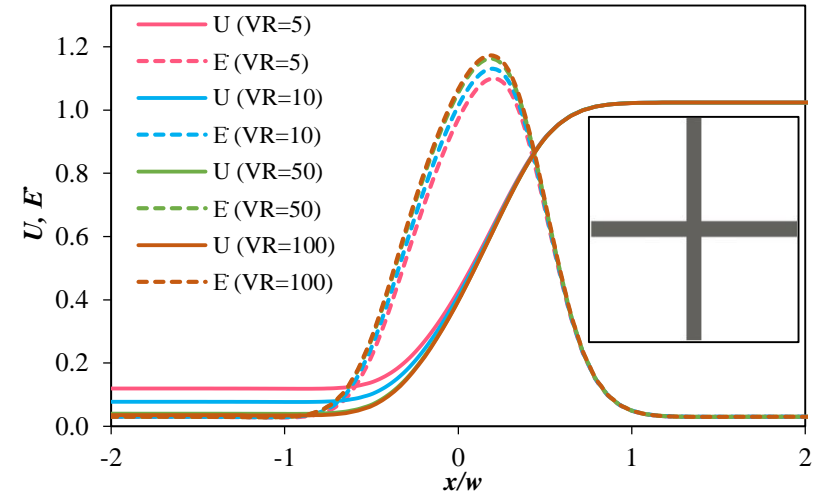
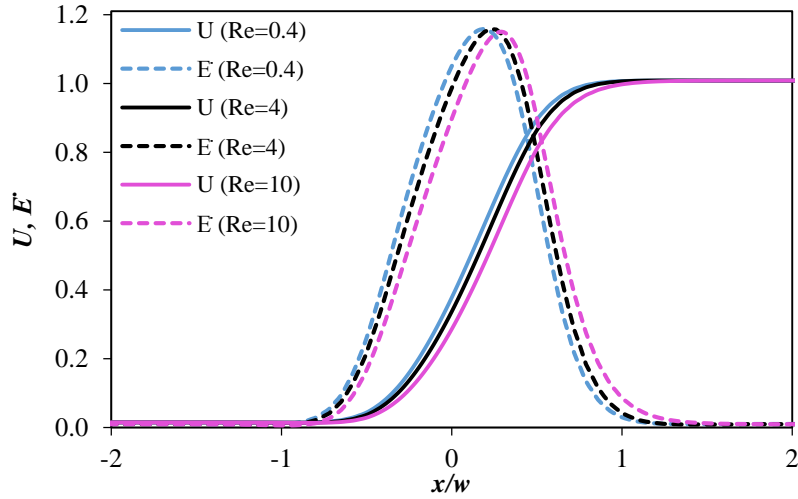

**3D\_AR1\_7w FFD**

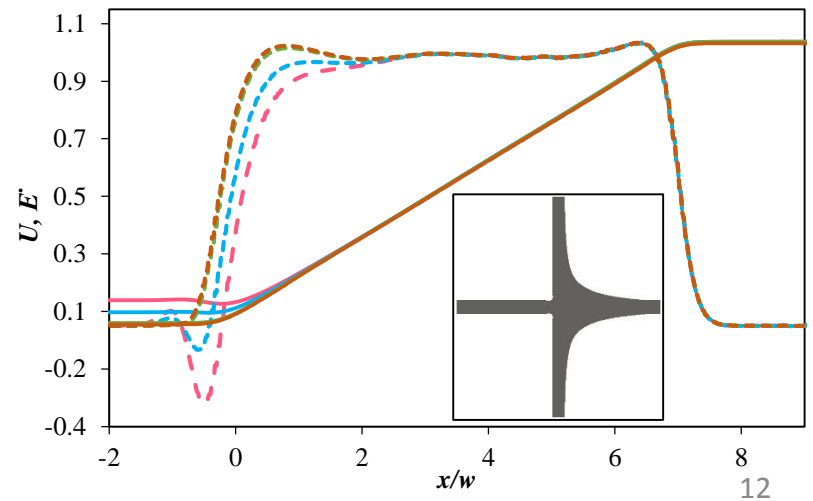
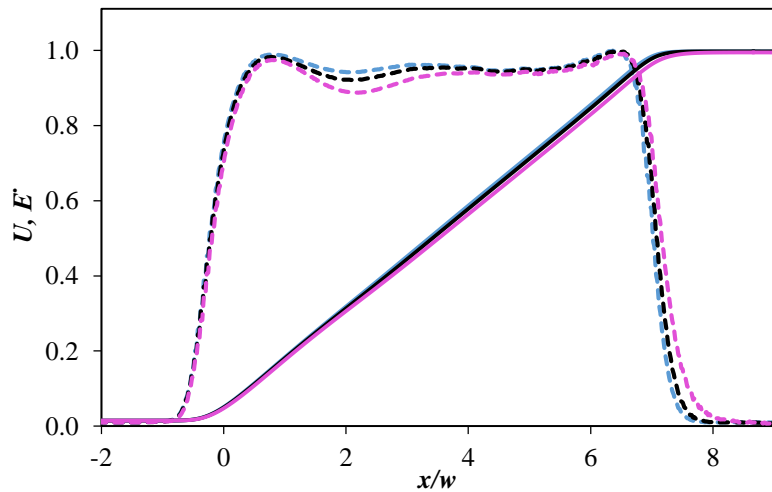

# Experimental validation

*Results:  $\mu$ -PIV*

**3D\_AR1\_5w**

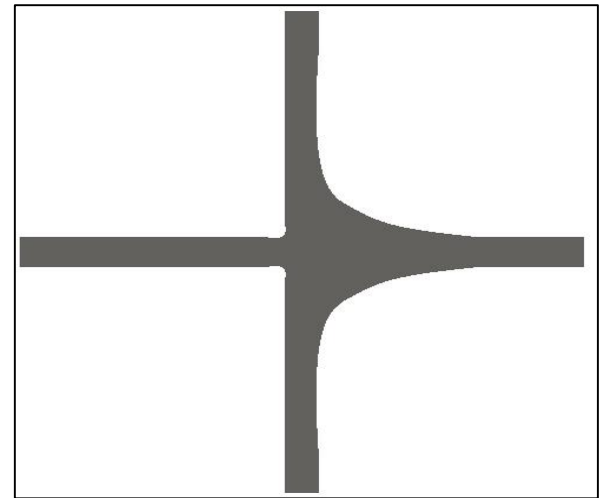
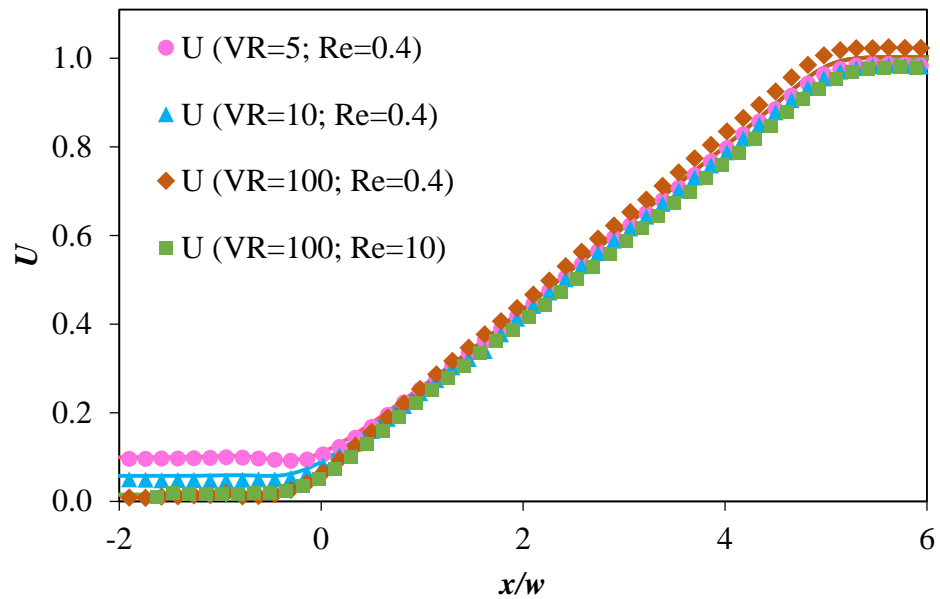

# Performance on viscoelastic flows

**Methods:** *model and parameters*

- ✓ *viscoelasticFluidFoam* solver of OpenFOAM;
- ✓ Oldroyd-B constitutive model;
- ✓  $\beta = \mu_S / (\mu_S + \mu_P) = 8/9$  (Boger fluid);
- ✓  $Re = 0.18$ ;
- ✓  $0 < We < 1.8$  ( $0 < El < 11$ );
- ✓ 2D optimized FFD.

# Performance on viscoelastic flows

**Results:** simulations

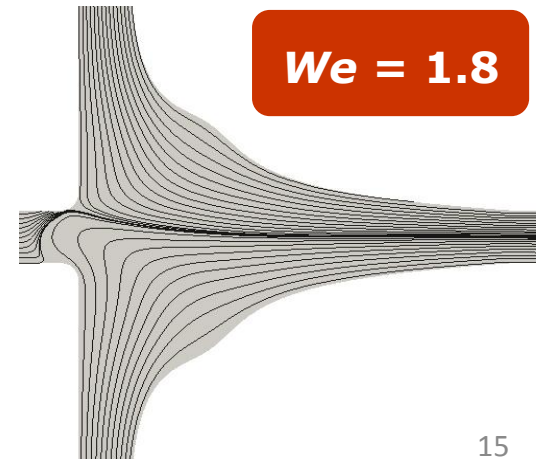
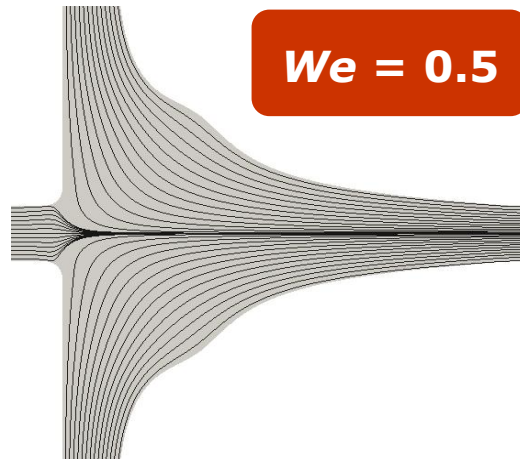
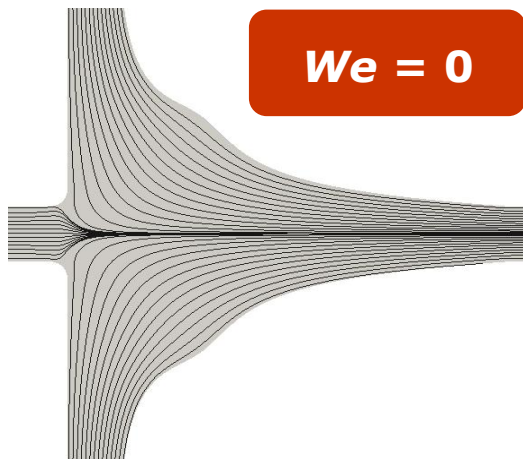
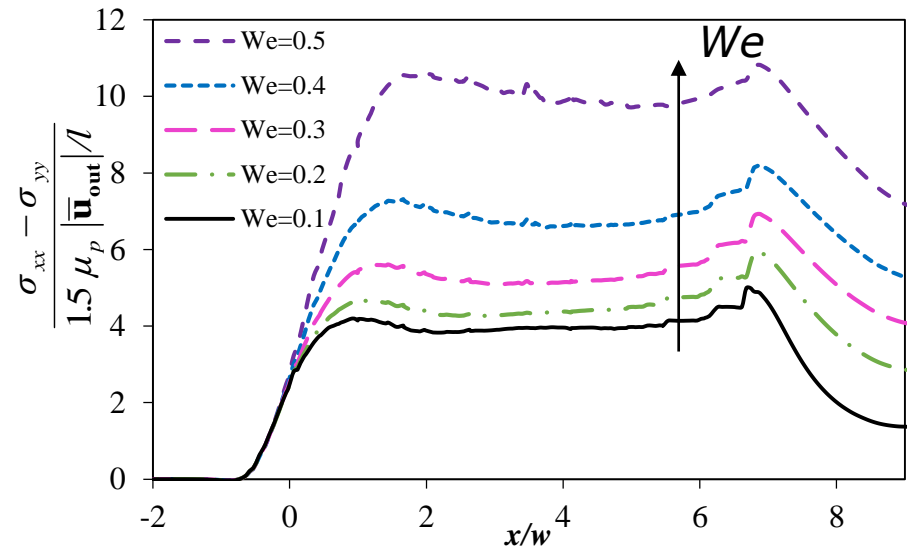
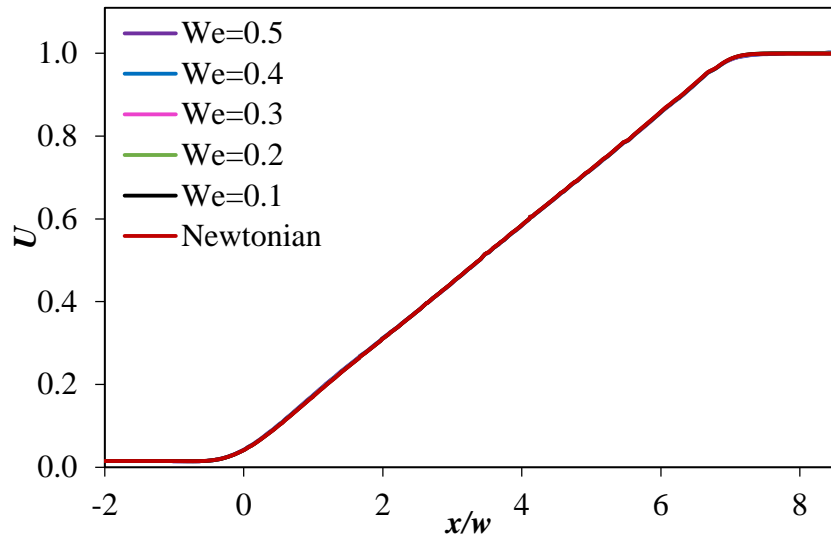

# Brownian dynamics simulations

**Methods:** *model and parameters*

- ✓  $\lambda$ -DNA: 21  $\mu\text{m}$  contour length, 4.3 s relaxation time (43 cP);
- ✓ Bead-spring model (11 beads, 10 springs)
  - Drag force;
  - Spring force;
  - Brownian motion;
  - Exclusion volume force;
- ✓ Motion equation: 
$$\frac{d\mathbf{x}_i}{dt} = \mathbf{u}(\mathbf{x}_i) + \frac{1}{\zeta} \left( \mathbf{F}_i^S + \mathbf{F}_i^B + \mathbf{F}_i^{EV} + \mathbf{F}_i^{HI} \right) ;$$
- ✓ Derived from *solidParticle* class of OpenFOAM.

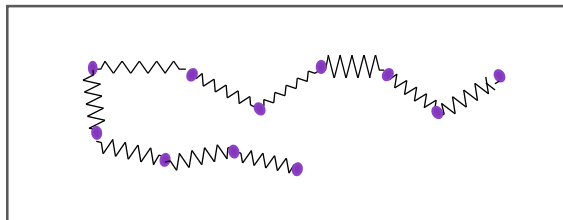

Bead-spring model

# Brownian dynamics simulations

**Results:** *simulations*

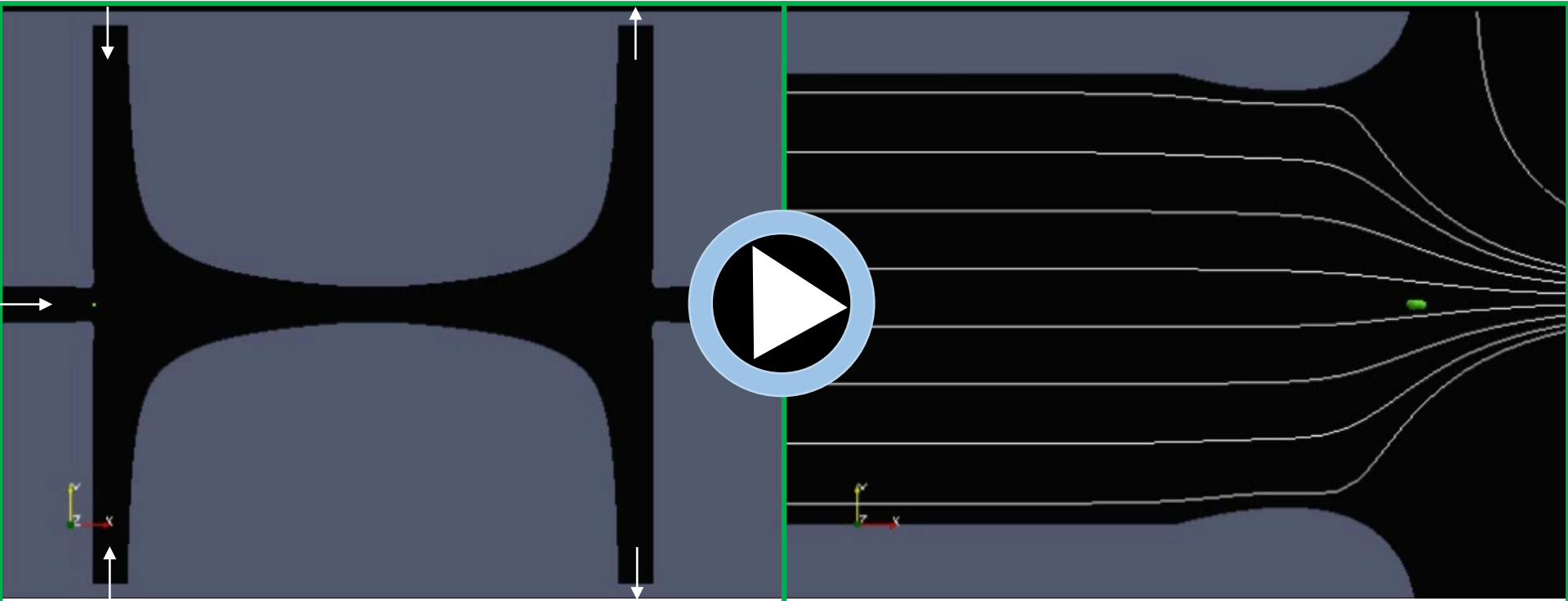

Illustrative example ( $VR = 100$ ,  $We = 50$ )

# Brownian dynamics simulations

**Results:** *simulations*

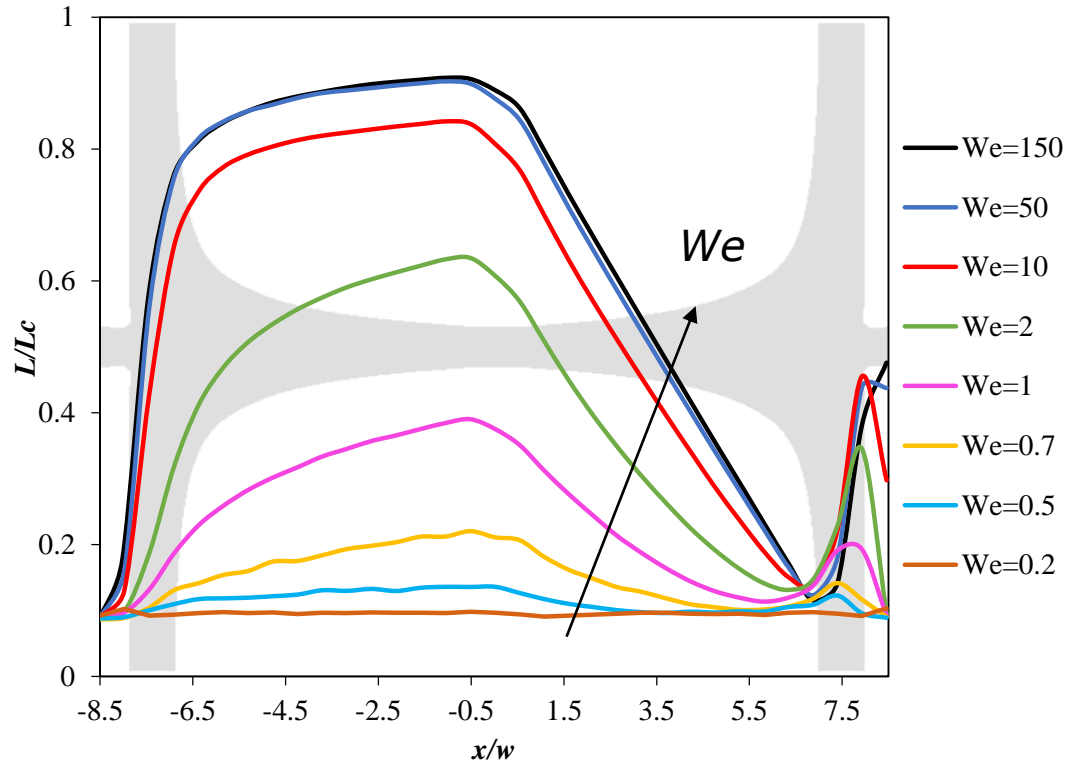

Average fractional length  
( $VR = 100$ )

# Summary

- Optimized devices (2D/3D) with good performance for  $VR > 5$  and  $Re < 10$ ;
- Simulated velocity profiles were experimentally validated.

- Promising results for micro-rheometry.

- Good performance on molecular stretching at high  $VR$ .

- **All the numerical simulations relied exclusively on open-source software.**

# Acknowledgements

Thank you for your attention !



**European Research Council**

Established by the European Commission

(Grant Agreement n. 307499)